

Service Facts

TSC048-SF-1

Customer Property: Contains wiring and service information. Please retain.

Library	Service Literature
Product Section	Unitary
Product	Package Air Conditioner
Model	TS
Literature Type	Service Facts
Sequence	1
Date	April 2001
File No.	SV-UN-RT-TSC048-SF-1 4/01
Supersedes	New

Models :

TSC048A1E0A0A
TSC048A1E1A0A
TSC048A1E2A0A
TSC048A1E3A0A
TSC048A1E4A0A
TSC048A1R0A0A
TSC048A1R1A0A
TSC048A1R2A0A
TSC048A1R3A0A
TSC048A1R4A0A

Packaged Electric/Electric 4 Ton Rooftop Units

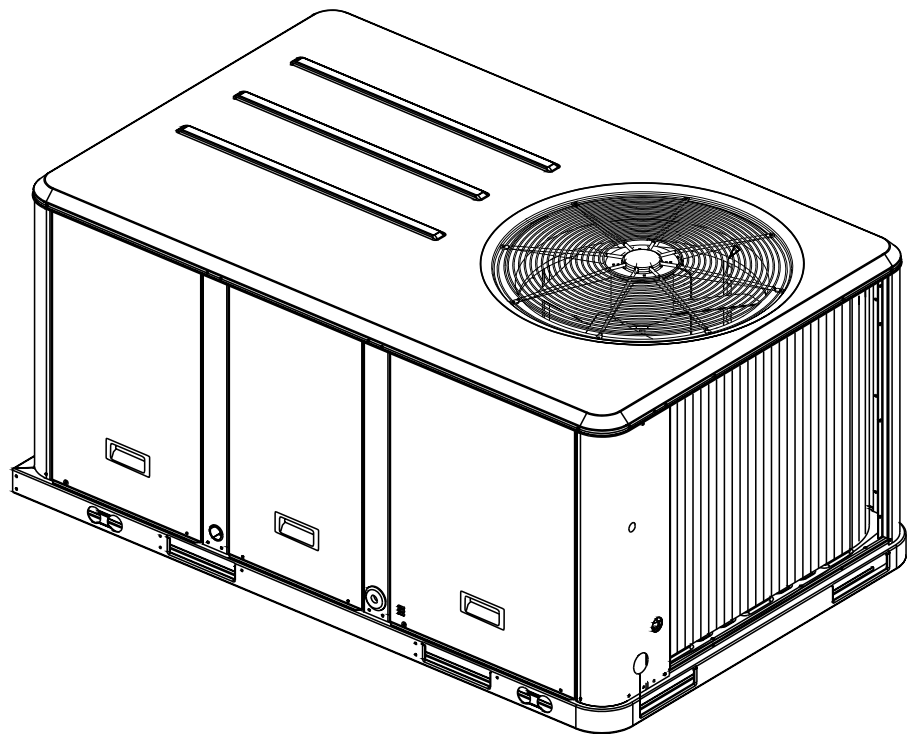

NOTICE

Warnings and Cautions appear at appropriate locations throughout this manual.
Read these carefully

WARNING: Indicates a potentially hazardous situation which, if not avoided, could result in death or serious injury.

CAUTION: Indicates a potentially hazardous situation which, if not avoided, may result in minor or moderate injury. It may also be used to alert against unsafe practices and where property-damage-only accidents could occur.

Since the manufacturer has a policy of continuous product improvement, it reserves the right to change design and specifications without notice.

Table of Contents

Product Specifications 3
Direct Drive Indoor Fan Option 4
Belt Drive Indoor Fan Option 5
Belt Drive Motor Sheave/ RPM 6
Economizer Pressure Drop 6
Filter Pressure Drop 6
Electric Heater Pressure Drop 6

Micro Electronic Sequence of Operation 7
ReliaTel Sequence of Operation 8

Standard Short Orifice Cooling Pressure Curve 10
Optional Expansion Valve Cooling Pressure Curve 10
Super Heat Chart 11
Refrigerant Circuit Diagram 12

Product Specifications

TSC048A1	208-230/60/1
Cooling Performance Gross Cooling Capacity BTUH ¹ SEER/EER ² Nominal CFM / ARI Rated CFM ARI Net Cooling Capacity Integrated Part Load Value System Power (KW)	50,300 10.1 1,600/1,600 48,000 --- 5.28
Power Connection Min. Circuit Ampacity Direct Drive - Standard / Oversize Fuse Size - Standard / Oversize	34.0/36.1 50/50
Compressor Number / Type Voltage R. L. Amp / L. R. Amp	1/Alliance Scroll 208-230/60/1 22.7/131.0
Sound Rating (BELS)	
Outdoor Coil - Type Tube Size (in.) OD Face Area (sq ft) Rows / FPI	Lanced 0.3125 6.17 2/17
Indoor Coil - Type Tube Size (in.) OD Face Area (sq ft) Rows / FPI Refrigerant Control ⁴ Drain Connection Size (in.)	Lanced 0.3125 6.68 3/16 Short Orifice or Expansion Valve 3/4"
Outdoor Fan - Type No. Used / Diameter (in.) Drive Type / No. Speeds CFM No. Motors / HP Motor RPM	Propeller 1/22 Direct/1 2850 1/0.33 1075
Direct Drive Indoor Fan -- Type No. Speeds Motor Frame Size Standard Motor Fan Diameter x Width (in.) Motor HP Motor RPM LO/Hi Tap High Static Motor Fan Diameter x Width (in.) Motor HP Motor RPM LO/Hi Tap	FC Centrifugal 2 48 11 x 11 0.50 930/1000 11 x 11 0.75 1000/1100
Filters - (No.) Size Recommended (in.) (lbs - R22) ³	Throwaway (2) 20 x 25 x 1 4.4

Footnotes:

1. Cooling Performance is rated at 95 F ambient, 80 F entering dry bulb, 67 F entering wet bulb and nominal cfm listed. ARI capacity is net and includes the effect of fan motor heat.
Base models are certified in accordance with the Unitary Air-Conditioner Equipment certification program, which is based on ARI Standard 210/240. All models tested in accordance with ARI Standard 210/240.
2. Rated at ARI conditions and in accordance with DOE test procedures.
3. Refrigerant charge shown is a nominal value, for a more precise value see the unit nameplate.

Direct Drive Indoor Fan Option

TS*048A

External Static Pressure (Inches of Water)

Model No.	Standard Motor					Oversized Motor			
	High Speed		Low Speed			High Speed		Low Speed	
Downflow	CFM	ESP	BHP	ESP	BHP	ESP	BHP	ESP	BHP
	1280	0.98	0.53	0.86	0.47	1.25	0.67	1.04	0.56
	1360	0.92	0.54	0.80	0.47	1.20	0.68	0.99	0.58
	1440	0.85	0.54	0.73	0.48	1.15	0.70	0.93	0.60
	1520	0.78	0.55	0.65	0.48	1.10	0.73	0.86	0.63
	1600	0.71	0.55	0.56	0.49	1.05	0.75	0.79	0.64
	1680	0.62	0.56	0.43	0.49	1.00	0.78	0.70	0.66
	1760	0.52	0.56	0.28	0.50	0.95	0.82	0.55	0.68
	1840	0.42	0.57	0.18	0.50	0.88	0.83	0.40	0.70
	1920	0.32	0.57	---	---	0.80	0.85	---	---

Model No.	Standard Motor					Oversized Motor			
	High Speed		Low Speed			High Speed		Low Speed	
Horizontal	CFM	ESP	BHP	ESP	BHP	ESP	BHP	ESP	BHP
	1280	0.93	0.53	0.81	0.47	1.20	0.67	0.99	0.56
	1360	0.87	0.54	0.75	0.47	1.15	0.68	0.94	0.58
	1440	0.80	0.54	0.68	0.48	1.10	0.70	0.88	0.60
	1520	0.73	0.55	0.60	0.48	1.05	0.73	0.81	0.63
	1600	0.66	0.55	0.51	0.49	1.00	0.75	0.74	0.64
	1680	0.57	0.56	0.38	0.49	0.95	0.78	0.65	0.66
	1760	0.47	0.56	0.23	0.50	0.90	0.82	0.50	0.68
	1840	0.37	0.57	0.13	0.50	0.83	0.83	0.35	0.70
	1920	0.27	0.57	---	---	0.75	0.85	0.25	0.73

NOTES:

1. Data includes pressure drop due to wet coil and factory installed standard filters.
2. Airflow performance at 230, 460, or 575 volts.
3. Fan Motor heat (Mbh) = 4.39 X Fan BHP
4. Factory supplied motors, in commercial equipment, are definite purpose motors, specifically designed and tested to operate reliably and continuously at all cataloged conditions. Using the full horsepower range of our fan motors as shown in our tabular data will not result in nuisance tripping or premature motor failure. Products warranty will not be affected.

Belt Drive Indoor Fan Option

TSC048A

Downflow Configuration

CFM	0.10		0.20		0.30		0.40		0.50		0.60		0.70		0.80		0.90		1.00	
	RPM	BHP	RPM	BHP	RPM	BHP	RPM	BHP	RPM	BHP	RPM	BHP	RPM	BHP	RPM	BHP	RPM	BHP	RPM	BHP
1 1/2 HP Standard Motor & Field Supplied Low Static Drive¹																				
1280	--	--	612	0.19	675	0.24	733	0.30	785	0.37	832	0.44	876	0.51	918	0.58	954	0.66	980	0.71
1440	--	--	658	0.23	715	0.29	770	0.36	821	0.43	869	0.50	913	0.58	953	0.65	991	0.73	1029	0.82
1600	650	0.24	705	0.29	758	0.36	810	0.42	859	0.50	906	0.57	948	0.65	989	0.73	1027	0.82	1063	0.91
1760	704	0.30	755	0.36	804	0.43	852	0.50	898	0.58	942	0.66	985	0.74	1026	0.83	1063	0.91	1099	1.01
1920	759	0.38	806	0.44	851	0.51	896	0.59	940	0.67	982	0.75	1023	0.84	1062	0.93	1100	1.03	1136	1.12

CFM	1.10		1.20		1.30		1.40		1.50	
	RPM	BHP	RPM	BHP	RPM	BHP	RPM	BHP	RPM	BHP
1 1/2 HP Standard Motor & Drive										
1280	1004	0.76	1028	0.81	1053	0.86	1079	0.92	1105	0.99
1440	1064	0.91	1087	0.97	1109	1.02	1131	1.08	1153	1.14
1600	1098	1.00	1132	1.10	1164	1.19	1192	1.28	1211	1.34
1760	1133	1.10	1167	1.20	1198	1.30	1229	1.40	--	--
1920	1170	1.22	1203	1.32	1233	1.42	--	--	--	--

TSC048A

Horizontal Configuration

CFM	0.10		0.20		0.30		0.40		0.50		0.60		0.70		0.80		0.90		1.00	
	RPM	BHP	RPM	BHP	RPM	BHP	RPM	BHP	RPM	BHP	RPM	BHP	RPM	BHP	RPM	BHP	RPM	BHP	RPM	BHP
1 1/2 HP Standard Motor & Field Supplied Low Static Drive¹																				
960	--	--	674	0.23	741	0.30	804	0.38	861	0.45	913	0.53	960	0.61	1003	0.69	1044	0.77	1081	0.85
1080	646	0.22	724	0.29	788	0.37	846	0.45	902	0.53	953	0.62	1001	0.70	1045	0.79	1086	0.88	1124	0.97
1200	700	0.29	773	0.36	836	0.45	891	0.53	943	0.62	993	0.72	1041	0.81	1085	0.90	1126	1.00	1165	1.10
1320	757	0.37	823	0.44	885	0.54	939	0.63	988	0.72	1035	0.82	1081	0.93	1125	1.03	1166	1.13	1205	1.24
1440	815	0.46	875	0.54	934	0.64	988	0.74	1035	0.84	1080	0.95	1123	1.06	1166	1.17	1206	1.28	1245	1.39

CFM	1.10		1.20		1.30		1.40		1.50	
	RPM	BHP	RPM	BHP	RPM	BHP	RPM	BHP	RPM	BHP
1 1/2 HP Standard Motor & Drive										
960	1119	0.94	1152	1.03	1186	1.11	1214	1.19	1241	1.27
1080	1160	1.06	1195	1.16	1228	1.25	1260	1.35	1291	1.44
1200	1202	1.20	1237	1.30	1270	1.40	1302	1.50	--	--
1320	1243	1.35	1279	1.45	--	--	--	--	--	--
1440	1282	1.50	--	--	--	--	--	--	--	--
1 1/2 HP Standard Motor & Field Supplied High Static Drive²										

Factory Supplied Motors, In Commercial Equipment, Are Definite Purpose Motors, Specifically Designed And Tested To Operate Reliably And Continuously At All Cataloged Conditions. Using The Full Horsepower Range Of Our Fan Motors As Shown In Our Tabular Data Will Not Result In Nuisance Tripping Or Premature Motor Failure. Our Product's Warranty Will Not Be Affected.

NOTES:

Data Includes Pressure Drop Due To Wet Coils And Filters.

Fan Motor Heat (MBH) = 3.15 x Fan BHP

1. Field Supplied Fan Sheave AK61 Required. Field Supplied Belt May Be Necessary.

2. Field Supplied Fan Sheave AK41 Required. Field Supplied Belt May Be Necessary.

Performance Specifications

Belt Drive Motor Sheave / Fan Speed

Standard Drive	Turns Open	5	4	3	2	1	Closed
	RPM	833	916	1000	1083	1167	1250

Economizer Pressure Drop

CFM	Static Pressure Drop (Inches of W.C.)		
	100% Outside Air	100% Return Air Downflow	100% Return Air Horizontal
	1280	0.081	0.025
1600	0.121	0.042	0.014
1920	0.170	0.064	0.022

Filter Pressure Drop

CFM	Filter Pressure Drop (Inches of W.C.)	
	Standard Filters	Optional Filters
	1 Inch	2 Inch
1280	0.04	0.04
1440	0.04	0.05
1600	0.05	0.06
1760	0.07	0.07
1920	0.08	0.09

Electric Heater Pressure Drop

kW Input Rating	5.0 kW	10.0 kW	13.8 kW
CFM	Static Pressure Drop (Inches of W. C.)		
1280	0.023	0.029	0.034
1440	0.029	0.036	0.043
1600	0.036	0.045	0.053
1760	0.043	0.054	0.064
1920	0.052	0.064	0.077
Temperature Rise Across Heater @ 1600 CFM			
	9.9	19.8	27.3

Note:

1. Temperature Rise = (Heater kW x 3414)/(1.08 x CFM)

Microelectronic Sequence of Operation

Sequence of Operation

These units are offered with two control options, Electro Mechanical and ReliaTel Controls. The ReliaTel Controls is a microelectronic control feature, which provides operating functions that are significantly different than conventional electro mechanical units.

Note: Refer to the unit nameplate. If the ninth digit of the model number equals "E" proceed with the following Sequence of Operation.

Electro Mechanical Control Cooling without an Economizer

When the thermostat switch is set to the "Cool" position and the zone temperature rises above the cooling setpoint, the thermostat Y contacts close. The compressor contactor (**CC1**) coil is energized provided the low pressure control (**LPC1**) and (**HPC1**) are closed. When the CC1 contacts close, compressor (**CPR1**) and the outdoor fan motor (**ODM**) start.

Electro Mechanical Evaporator Fan Operation

When the thermostat fan selection switch is set to the "Auto" position, the thermostat energizes the indoor fan relay (**F**) coil to start the indoor fan motor (**IDM**).

The control box timer de-energizes the fan relay (**F**) approximately 80 seconds after the cooling requirement has been satisfied to enhance unit efficiency. When the heating cycle is terminated, the indoor fan relay (**F**) coil is de-energized with heater contactors.

When the thermostat fan selection switch is set to the "On" position, the thermostat keeps the indoor fan relay coil (**F**) energized for continuous fan motor operation.

Economizer Set-Up

Adjusting the minimum position potentiometer located on the unit economizer actuator (ECA) sets the required amount of ventilation air.

The suitability of the outside air can be selected utilizing the enthalpy potentiometer on the ECA, as described below:

1. Ambient Temperature - controlling the economizing cycle by sensing the outside air dry bulb temperature. The table below lists the selectable dry bulb values by potentiometer setting.

Potentiometer Setting	Dry Bulb	Enthalpy
A	73*	27
B	70	25
C	67	23
D	63	22

* Factory Setting

Electro Mechanical Control Cooling with an Economizer

The economizer is utilized to control the zone temperature providing the outside air conditions are suitable. Outside air is drawn into the unit through a modulating damper. When cooling is required and economizing is possible, the unit economizer actuator (**ECA**) opens the economizer damper. The ECA continues to modulate the economizer damper open/closed to keep the mixed air temperature in the 50 F to 55 F range.

The thermostat will close the Y contacts to turn on contactor (**CC1**) if mechanical cooling is required.

If economizing is not possible, the ECA drives the damper to the minimum position setpoint when the indoor fan relay (**F**) is energized and allows mechanical cooling operation.

Electro Mechanical Control Heating Operation

When the system switch is set to the "Heat" position and the zone temperature falls below the heating setpoint, the thermostat closes W1 contacts the first stage electric heat contactor (**AH or AH & CH**) is energized.

If the first stage of electric heat can not satisfy the heating requirement, the thermostat closes W2. When the W2 contacts close, the second stage electric heat contactor (**BH or BH & DH**) is energized, if applicable. The thermostat cycles

ReliaTel

Sequence of Operation

both the first and second stages of heat “On” and “Off” as required to maintain the zone temperature setpoint.

Sequence of Operation

These units are offered with two control options, Electro Mechanical and ReliaTel Controls. The ReliaTel Controls is a microelectronic control feature, which provides operating functions that are significantly different than conventional electro mechanical units. The master module is the ReliaTel Refrigeration Module (**RTRM**).

Note: Refer to the unit nameplate. If the ninth digit of the model number equals “R” proceed with the following Sequence of Operation.

The RTRM provides compressor anti-short cycle timing functions through minimum “Off” and “On” timing to increase reliability, performance and to maximize unit efficiency.

Upon power initialization, the RTRM performs self-diagnostic checks to insure that all internal controls are functioning. It checks the configuration parameters against the components connected to the system.

The LED located on the RTRM module is turned “On” within one second after power-up if all internal operations are okay.

ReliaTel Control Cooling without an Economizer

When the system switch is set to the “Cool” position and the zone temperature rises above the cooling setpoint controlband, the RTRM energizes the (**K9**) relay coil located on the RTRM. When the K9 relay contacts close, the compressor contactor (**CC1**) coil is energized provided the low pressure control (**LPC1**) and (**HPC1**) are closed. When the CC1 contacts close, compressor (**CPR1**) and the outdoor fan motor (**ODM**) start to maintain the zone temperature to within ± 2 F of the sensor setpoint at the sensed location.

ReliaTel Control Evaporator Fan Operation

When the fan selection switch is set to the “Auto” position, the RTRM energizes the (**K6**) relay coil approximately 1 second after energizing the compressor contactor coil (**CC1**) in the cooling mode. In the heating mode, the RTRM energizes the (**K6**) relay coil approximately 1 second before energizing the electric heat contactors. Closing the **K6** contacts on the RTRM energizes the indoor fan relay (**F**) coil to start the indoor fan motor (**IDM**).

The RTRM de-energizes the fan relay (**F**) approximately 60 seconds after the cooling requirement has been satisfied to enhance unit efficiency. When the heating cycle is terminated, the indoor fan relay (**F**) coil is de-energized at the same time as the heater contactors.

When the fan selection switch is set to the “On” position, the RTRM keeps the indoor fan relay coil (**F**) energized for continuous fan motor operation.

When the unit is equipped with the optional fan failure switch, wired between terminals J7-10 and J7-11 on the ReliaTel Options Module (**RTOM**), the **RTRM** produces an analog output if the fan failure switch (**FFS**) does not open within two minutes after a request for fan operation. When the system is connected to a remote panel, the “SERVICE” LED will be turned on when this failure occurs.

Low Ambient Operation (ReliaTel Control Only)

During low ambient operation, outside air temperature below 55 F, the RTRM will cycle the compressor and outdoor fan motor “Off” for approximately 3 minutes after every 10 minutes of accumulated compressor run time. The indoor fan motor (**IDM**) will continue to operate during this evaporator defrost cycle (**EDC**) and the compressor and outdoor fan will return to normal operation once the defrost cycle has terminated and the compressor “Off” time delay has been satisfied.

ReliaTel Control Cooling with an Economizer

The economizer is utilized to control the zone temperature providing the outside air conditions are suitable. Outside air is drawn into the unit through modulating dampers. When cooling is required and economizing is possible, the RTRM sends the cooling request to the unit economizer actuator (**ECA**) to open the economizer damper. The RTRM tries to cool the zone utilizing the economizer to slightly below the zone temperature setpoint. If the mixed air sensor (**MAS**) senses that the mixed air temperature is below 53 F, the damper modulate toward the closed position. If the zone temperature continues to rise above the zone temperature setpoint controlband and the economizer damper is fully open, the RTRM energizes the compressor contactor (**CC1**).

The ECA continues to modulate the economizer damper open/closed to keep the mixed air temperature that is calculated by the RTRM.

If economizing is not possible, the ECA drives the damper to the minimum position setpoint when the indoor fan relay (**F**) is energized and allows mechanical cooling operation.

When the unit is equipped with the optional fan failure switch, wired between terminals J7-10 and J7-11 on the **RTOM**, the **RTRM** will stop all cooling functions and produce an analog output if the fan failure switch (**FFS**) does not open within 40 seconds after a request for fan operation. When the system is connected to a remote panel, the “SERVICE” LED will flash when this failure occurs.

Economizer Set-Up

Adjusting the minimum position potentiometer located on the unit economizer actuator (ECA) sets the required amount of ventilation air.

Two of the three methods for determining the suitability of the outside air can be selected utilizing the enthalpy potentiometer on the ECA, as described below:

1. Ambient Temperature - controlling the economizing cycle by sensing the outside air dry bulb temperature. The

ReliaTel

Sequence of Operation

table below lists the selectable dry bulb values by potentiometer setting.

2. Reference Enthalpy - controlling the economizer cycle by sensing the outdoor air humidity. The table below lists the selectable enthalpy values by potentiometer setting. If the outside air enthalpy value is less than the selected value, the economizer is allowed to operate.
3. Comparative Enthalpy - By utilizing a humidity sensor and a temperature sensor in both the return air stream and the outdoor air stream, the unit control processor (**RTRM**) will be able to establish which conditions are best suited for maintaining the zone temperature, i.e. indoor conditions or outdoor conditions. The potentiometer located on the ECA is non-functional when both the temperature and humidity sensors are installed.

Potentiometer Setting	Dry Bulb	Enthalpy
A	73*	27
B	70	25
C	67	23
D	63	22

* Factory Setting

ReliaTel Control Heating Operation

When the system switch is set to the "Heat" position and the zone temperature falls below the heating setpoint controlband, the RTRM energizes **K1** relay coil. When the **K1** relay contacts close, located on the RTRM, the first stage electric heat contactor (**AH or AH & CH**) is energized.

If the first stage of electric heat can not satisfy the heating requirement, the RTRM energizes **K2** relay coil. When the **K2** relay contacts close, located on the RTRM, the second stage electric heat contactor (**BH or BH & DH**) is energized, if applicable. The RTRM cycles both the first and second stages of heat "On" and "Off" as required to maintain the zone temperature setpoint.

Refrigeration Data

**SHORT ORIFICE
COOLING CYCLE PRESSURE CURVE**
(Based on Indoor Airflow of 400 CFM / Ton)

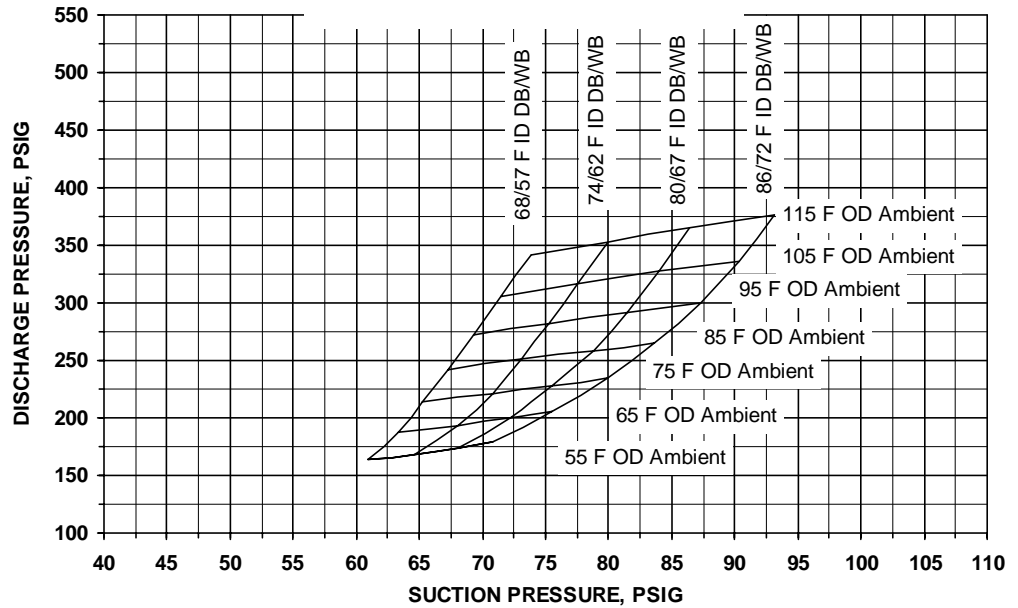

To Check Operating Pressures

1. Start the unit and allow the pressures to stabilize.
2. Measure the indoor DB/WB temperature entering the indoor coil.
3. Measure the outdoor air dry bulb temperature
4. Take discharge and suction pressure readings.
5. Plot the outdoor dry bulb and the indoor DB/WB temperature onto the chart.
6. At the point of intersection, read down for the suction pressure and to the left for the discharge pressure.

**OPTIONAL EXPANSION VALVE
COOLING CYCLE PRESSURE CURVE**
(Based on Indoor Airflow of 400 CFM / Ton)

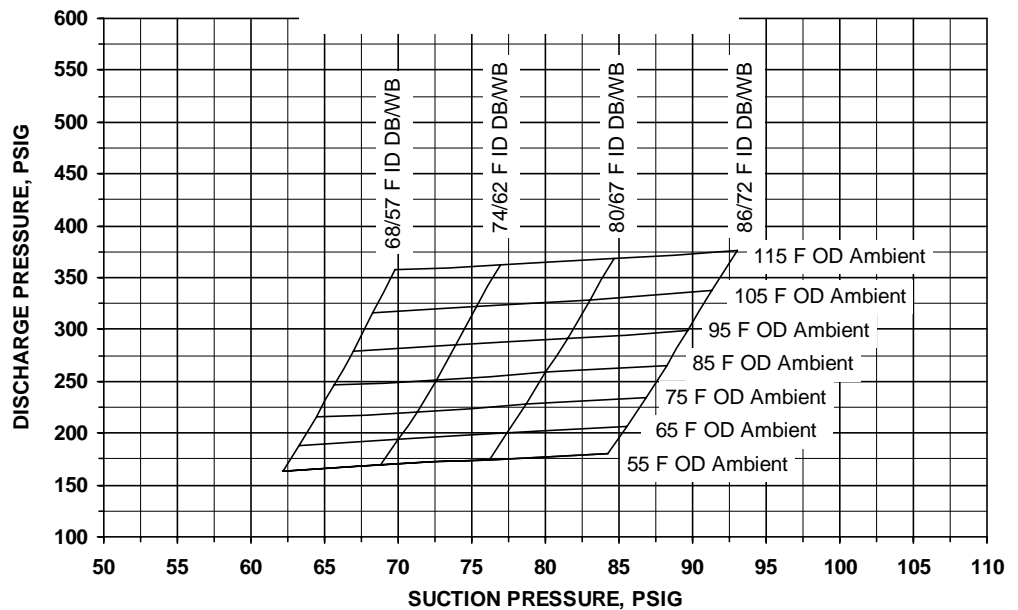

To Check Operating Pressures

1. Start the unit and allow the pressures to stabilize.
2. Measure the indoor DB/WB temperature entering the indoor coil.
3. Measure the outdoor air dry bulb temperature
4. Take discharge and suction pressure readings.
5. Plot the outdoor dry bulb and the indoor DB/WB temperature onto the chart.
6. At the point of intersection, read down for the suction pressure and to the left for the discharge pressure.

Refrigeration Data

SUPERHEAT CHARGING CHART
(Based on Indoor Airflow of 400 CFM / Ton)

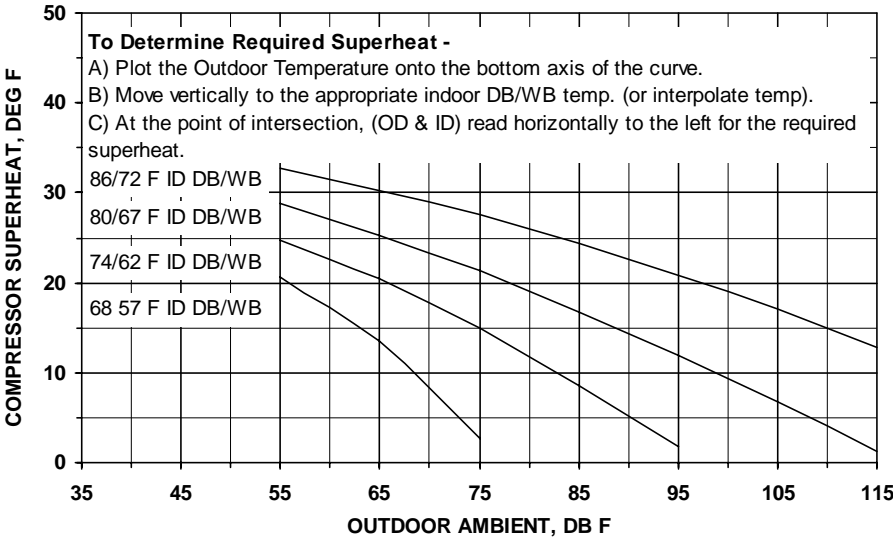

- 1) REFRIGERANT CHARGE - ADD if the superheat is more than 5 F above curve value.
 - REDUCE if the superheat is more than 5 F below curve value.
 - OK if the superheat is within 5 F of curve value.
- 2) Do not add refrigerant if the superheat is less than 5 F.
- 3) Curves are based on 400 CFM/Ton Indoor Airflow @ 50% R.H.
- 4) System must be running at stabilized conditions before measuring superheat.

Mechanical Data

Refrigerant Circuit Diagram

⚠ CAUTION

CONTAINS REFRIGERANT!

SYSTEM CONTAINS OIL AND REFRIGERANT UNDER HIGH PRESSURE. RECOVER REFRIGERANT TO RELIEVE PRESSURE BEFORE OPENING THE SYSTEM.

Failure to follow proper procedures can result in personal illness or injury or severe equipment damage.

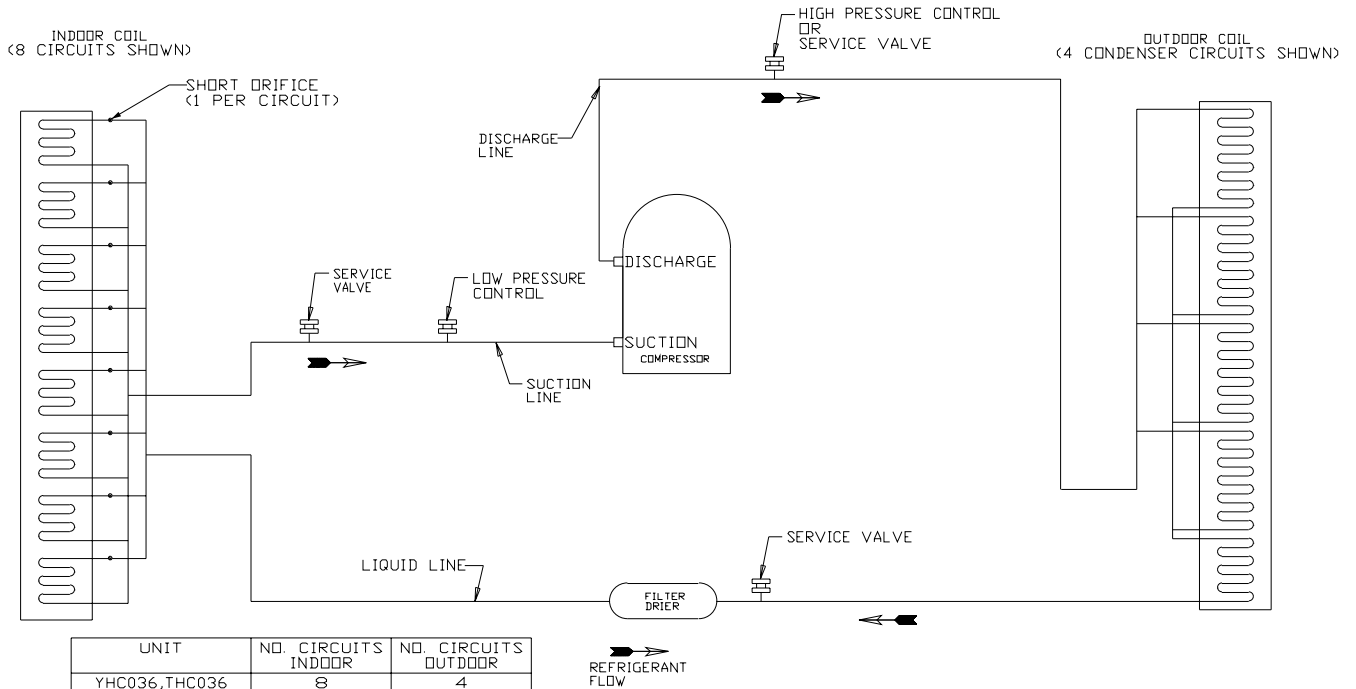

UNIT	NO. CIRCUITS INDOOR	NO. CIRCUITS OUTDOOR
YHC036,THC036	8	4
YSC048A1,TSC048A1	10	4
YSC048A3,TSC048A3	9	4
YHC048,THC048	10	6
YSC060,TSC060	12	6
YHC060,THC060	12	7

4366-1312A